

User manual

COMASTER STC1000 V1.00

UASAGE NOTICE

This software / document / material are property of Kurolikar Automation Research Labs (KARL PL) Pvt Ltd. It has been provided for the exclusive use of customers for the products of KARL PL. It must not be copied, saved or duplicated in full or in part in any form without the written permission of KARL PL. Unauthorized copying, duplication or reproduction of this material is restricted and may attract severe legal penalties.

The specifications and features mentioned in this document are available at the time this document was prepared. Utmost care has been taken to maintain accuracy and consistency of the information. However KARL PL does not guarantee this document to be free from errors and use of the information is at sole responsibility of the user. KARL PL reserves the right to change or modify this document at any time without prior notice

INDEX

- 1. Introduction**
- 2. Features**
- 3. Applications**
- 4. Electrical Specifications**
- 5. Board Layout & Wiring Diagram**
- 6. Warranty Statement**

1. Introduction



COMASTER STC1000 unit is used for controlling up to three stepper motors. The unit uses standard pulse / direction mode for controlling all three motors. Stepper drive need to be connected externally and a separate power supply is required for the motor. STC1000 requires external 12V power supply and has limit switch inputs. It can be controlled over RS232 serial communication from host such as computer.

STC1000 also comes with three built-in encoder channels. Each of the encoder channel corresponds to a stepper motor. This way, the motion can be monitored and controlled in closed loop.

2. Features

- ❖ Three Stepper Motor channels.
- ❖ Eight digital inputs with limit switch input for controller.
- ❖ RS232 serial interface with settable baud rate
- ❖ STC1000 requires external 12V power supply

3. Applications

- ❖ Multi gauging System
- ❖ Measuring Fixture
- ❖ Testing Fixture

4. Electrical Specifications

- **Power supply**

Board is powered from 12V DC source. Power source should be capable of sourcing at least 200mA current.

- **Digital inputs**

There is provision for 8 digital inputs which can take from 0V to 12V DC signal.

- **Stepper interface**

Eight outputs for Three channels. Stepper motor pulse/direction +5v supply and GND etc. control is provided. If direction is set to HIGH, DIR pin provides +5V and approx. 0V for LOW.

- **Communication settings**

Baud rate: Settable as 9600, 19200, 38400, 57600 (Factory default is 19200)

5. BOARD LAYOUT & WIRING DIAGRAM

- **Board layout notations meaning**

Serial No	Designation	Description
1	12V DC	Power supply to board from 12V SMPS
2	24V DC	Power supply to board from 24V SMPS
3	PUL	Pulse
4	DIR	Direction
5	I1,I2,I3,I4,.....I8	Digital inputs

Table-1

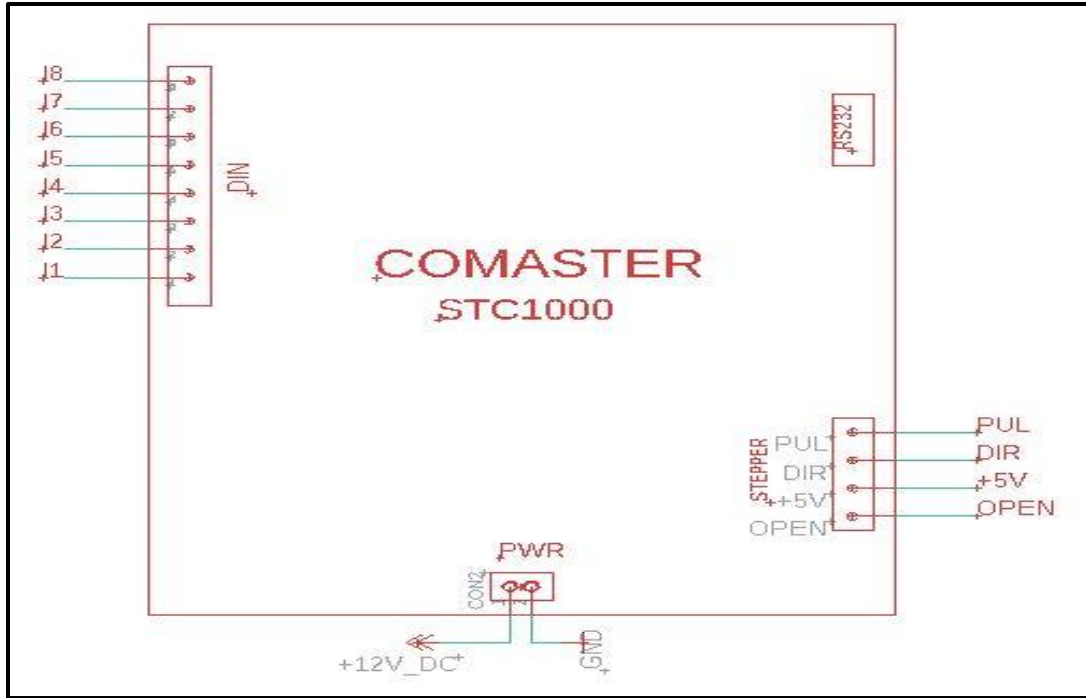

Image-1

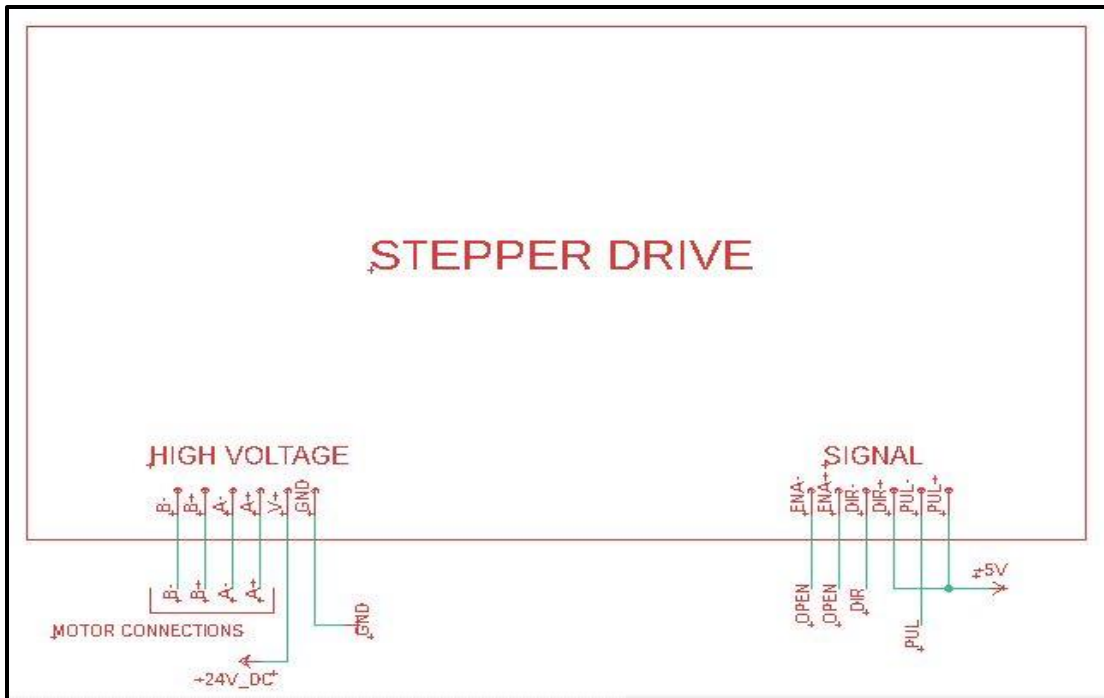

Image-2

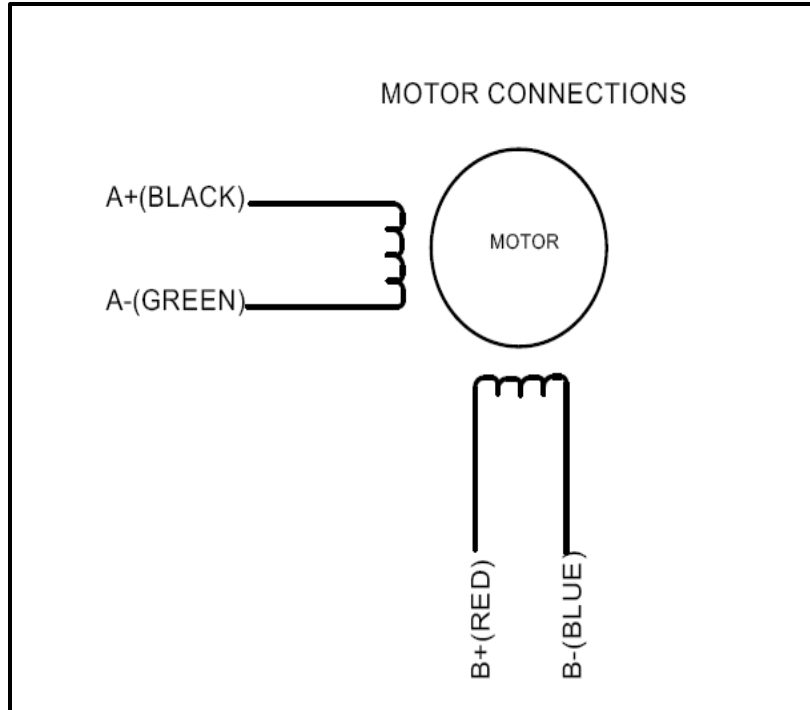

Image-3

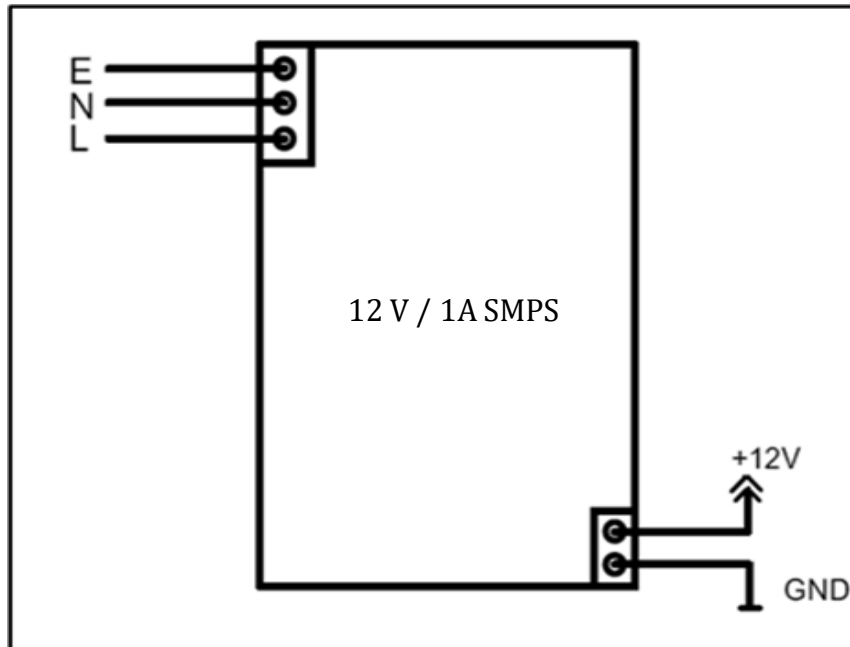

Image-4

Warranty statement

All the products are covered under warranty for a period of 12 months against manufacturing defects, workmanship and malfunction under normal operating conditions. The warranty is subject to the terms and conditions mentioned below.

1. The warranty commences from the date of sale for a period of 12 months irrespective of the actual installation date.
2. The warranty is against manufacturing defects and any subsequent malfunction of the instrument during the normal operation. The warranty shall not be applicable in case of accidental damage, damage due to wrong operation, connection or conditions that are out of normal operating specifications.
3. KARL PL, at its discretion may repair or replace the product depending on the condition of instrument, availability of spare parts and type of failure.
4. In case of warranty claim, the warranty period will not be extended and remains same as stated earlier from the date of sale.
5. Maximum liability of KARL PL remains up to repair or replacement of the product only. Any damages or losses raised out of use of the instrument are not covered by this warranty. In any case, cost of the product will not be refunded.
6. In case of warranty claim, the product should be sent over to KARL PL immediately after noticing the defect or failure. A detailed note of operating conditions in which fault occurred will be helpful in rectifying the defect.
7. Do not try to open or repair the instrument on your own. Warranty will stand null and void in such case. Products with tampered warranty seal will not be considered for warranty claims and regular service charges will be applicable.
8. In all claims, the company's decision will be final and legally binding.
9. Any and all disputes are subject to pune jurisdiction only.

Kurolikar Automation Research Labs Pvt Ltd
#226, Laxmi colony, Behind manish market,
Hadapsar, Pune - 411028.
www.AutomationResearchLabs.com
Email: sales@AutomationResearchLabs.com